

Safety Mat UMA Series

Easy-to-install safety mat with advanced features

- 1 and 2 cable types
- Meets EN ISO 13849-1 (PLd/Safety Category 3) and EN ISO 13856-1
- Can be used with MC3 Safety Mat Controller, SCC-1224A Safety Mat/Edge Controller or NX Safety Controller
- Complies with North American safety standards including ANSI/RIA 15.06



Model Number Structure

U M A - - -

1 2 3 4 5

1. Measurement Unit

None: Inch

M: mm

2. Color

None: Black

Y: Yellow

3. Safety Mat Dimension A

4. Safety Mat Dimension B

5. Number of Cables

1: 1 cable (4-wire type)

2: 2 cables (2-wire type)

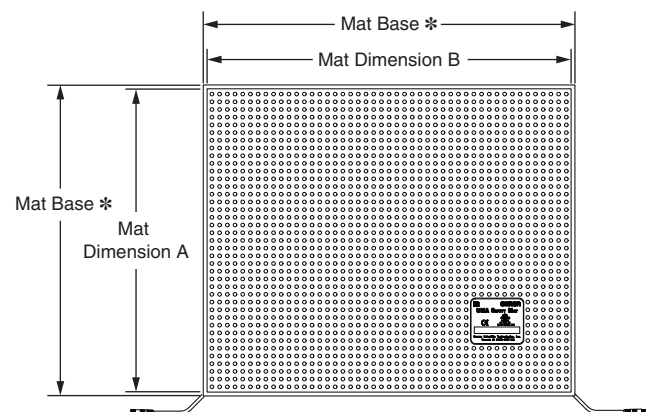

* Refer to *Mat Dimensions* for the dimensions of the mat base.

UMA Series

Ordering Information

Safety Mats



1-cable Mats

Appearance	Dimensions		Black	Yellow
	A (mm)	B (mm)	Model	Model
	300	300	UMMA-0300-0300-1	UMMYA-0300-0300-1
	400	400	UMMA-0400-0400-1	UMMYA-0400-0400-1
	500	250	UMMA-0500-0250-1	UMMYA-0500-0250-1
	500	400	UMMA-0500-0400-1	UMMYA-0500-0400-1
	500	500	UMMA-0500-0500-1	UMMYA-0500-0500-1
	500	1500	UMMA-0500-1500-1	UMMYA-0500-1500-1
	600	400	UMMA-0600-0400-1	UMMYA-0600-0400-1
	750	250	UMMA-0750-0250-1	UMMYA-0750-0250-1
	750	500	UMMA-0750-0500-1	UMMYA-0750-0500-1
	750	750	UMMA-0750-0750-1	UMMYA-0750-0750-1
	750	1500	UMMA-0750-1500-1	UMMYA-0750-1500-1
	1000	500	UMMA-1000-0500-1	UMMYA-1000-0500-1
	1000	750	UMMA-1000-0750-1	UMMYA-1000-0750-1
	1000	1000	UMMA-1000-1000-1	UMMYA-1000-1000-1
	1000	1250	UMMA-1000-1250-1	UMMYA-1000-1250-1
1000	1500	UMMA-1000-1500-1	UMMYA-1000-1500-1	

2-cable Mats

Appearance	Dimensions		Black	Yellow
	A (mm)	B (mm)	Model	Model
	300	300	UMMA-0300-0300-2	UMMYA-0300-0300-2
	400	400	UMMA-0400-0400-2	UMMYA-0400-0400-2
	500	250	UMMA-0500-0250-2	UMMYA-0500-0250-2
	500	400	UMMA-0500-0400-2	UMMYA-0500-0400-2
	500	500	UMMA-0500-0500-2	UMMYA-0500-0500-2
	500	1500	UMMA-0500-1500-2	UMMYA-0500-1500-2
	600	400	UMMA-0600-0400-2	UMMYA-0600-0400-2
	750	250	UMMA-0750-0250-2	UMMYA-0750-0250-2
	750	500	UMMA-0750-0500-2	UMMYA-0750-0500-2
	750	750	UMMA-0750-0750-2	UMMYA-0750-0750-2
	750	1500	UMMA-0750-1500-2	UMMYA-0750-1500-2
	1000	500	UMMA-1000-0500-2	UMMYA-1000-0500-2
	1000	750	UMMA-1000-0750-2	UMMYA-1000-0750-2
	1000	1000	UMMA-1000-1000-2	UMMYA-1000-1000-2
	1000	1250	UMMA-1000-1250-2	UMMYA-1000-1250-2
1000	1500	UMMA-1000-1500-2	UMMYA-1000-1500-2	

Trims

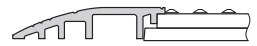
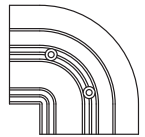
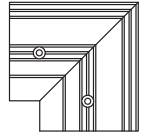
Appearance	Name	Model	Remarks
	Ramp Trim with Yellow PVC Cover (1.22 m)	UMRT4	Installed on the perimeter of the Safety Mat. Each Trim is composed of two parts, an aluminum base and a PVC Cover. Possible to install cables inside.
	Ramp Trim with Yellow PVC Cover (2.44 m)	UMRT8	
	Joining Trim (1.22 m)	UMJS4	The Joining Trims join the Safety Mats when two or more Safety Mats are being combined. In addition to joining the Safety Mats, the Joining Trims preserve the Safety Mat's sensitivity at the joints. Possible to install cables inside except M8 connector portion.
	Joining Trim (2.44 m)	UMJS8	
	Aluminum Ramp Trim (2.44 m)	UMAL	Installed on the perimeter of the Safety Mat.
	Molded Outside Corner	UMOC	Installed at the outside corners of the Safety Mat combining with Ramp Trims with Yellow PVC Cover.
	Molded Inside Corner	UMIC	Installed at the inside corners when two or more Safety Mats combining with Ramp Trims with Yellow PVC Cover are being combined.

Note: 12 screws (No. 8-32 × 1.25") and 12 anchors are included with Ramp Trim with Yellow PVC Cover (UMRT4 and UMRT8) and Aluminum Ramp Trim (UMAL).

Trim Kits (Not Including Safety Mat)

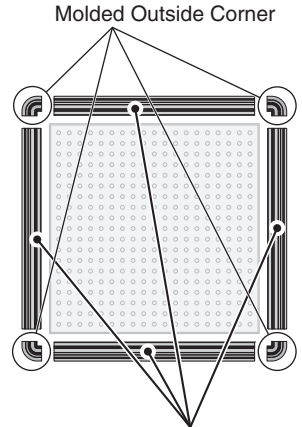
Applicable Safety Mat		Trim Kit model	Remarks
Black	Yellow		
UMMA-0300-0300-□	UMMYA-0300-0300-□	MTKCA-0300-0300	A set of Molded Outside Corners and Trims <ul style="list-style-type: none"> • 4 UMOC Molded Outside Corners • 4 Ramp Trims with Yellow PVC Corners that fit the mat dimensions A and B 
UMMA-0400-0400-□	UMMYA-0400-0400-□	MTKCA-0400-0400	
UMMA-0500-0250-□	UMMYA-0500-0250-□	MTKCA-0500-0250	
UMMA-0500-0400-□	UMMYA-0500-0400-□	MTKCA-0500-0400	
UMMA-0500-0500-□	UMMYA-0500-0500-□	MTKCA-0500-0500	
UMMA-0500-1500-□	UMMYA-0500-1500-□	MTKCA-0500-1500	
UMMA-0600-0400-□	UMMYA-0600-0400-□	MTKCA-0600-0400	
UMMA-0750-0250-□	UMMYA-0750-0250-□	MTKCA-0750-0250	
UMMA-0750-0500-□	UMMYA-0750-0500-□	MTKCA-0750-0500	
UMMA-0750-0750-□	UMMYA-0750-0750-□	MTKCA-0750-0750	
UMMA-0750-1500-□	UMMYA-0750-1500-□	MTKCA-0750-1500	
UMMA-1000-0500-□	UMMYA-1000-0500-□	MTKCA-1000-0500	
UMMA-1000-0750-□	UMMYA-1000-0750-□	MTKCA-1000-0750	
UMMA-1000-1000-□	UMMYA-1000-1000-□	MTKCA-1000-1000	
UMMA-1000-1250-□	UMMYA-1000-1250-□	MTKCA-1000-1250	
UMMA-1000-1500-□	UMMYA-1000-1500-□	MTKCA-1000-1500	



Note: 1. Put 1 in the box (□) in the model number for 1-cable Mat or 2 for 2-cable Mat.

2. 24 screws (No. 8-32 × 1.25") and 24 anchors are included with a Trim Kit.

3. The length of the Ramp Trims with Yellow PVC Covers has been made to fit mat dimensions A and B.
 PVC Trim Cover = (Mat dimensions A and B) - 50.8 mm

UMA Series

Safety Mat Controller

Product	Appearance	Safety outputs	Auxiliary outputs	Rated voltage	Terminal block type	Model
Safety Mat Controller		SPDT-NO	SPDT-NC	24 VDC	Screw terminals	MC3
Safety Mat/Edge Controller *		SPDT-NO	SPST-NO	120 VAC or 24 VAC/DC	Screw terminals	SCC-1224A

* Can also be connected with SGE-series Safety Edges.



Refer to the *SCC-1224A Safety Mat/Edge Controller User Manual* (Cat. No. Z394) for details.

Accessories

Using with 1-cable Mats

Connecting a 1-cable Mat to a MC3 Safety Mat Controller, SCC-1224A Safety Mat/Edge Controller or NX-series Safety Controller.



Cables

Appearance	Name	Length	Remarks	Model
	Single Connector Cable	2 m	Single connector cable to connect a 1-cable Mat (UM□□A-□-□-1) to a Controller. M8, 4-socket	UMA-CBL-4PCF-M8-02M
		5 m		UMA-CBL-4PCF-M8-05M
		10 m		UMA-CBL-4PCF-M8-10M
	Male-Female Extension Cable	2 m	Extension cable to connect a 1-cable Mat (UM□□A-□-□-1) to a Controller. M8, 4-pin	UMA-CBL-4PMF-M8-02M
		5 m		UMA-CBL-4PMF-M8-05M
		10 m		UMA-CBL-4PMF-M8-10M

Using with 2-cable Mats



Connecting a 2-cable Mat to a MC3 Safety Mat Controller, SCC-1224A Safety Mat/Edge Controller or NX-series Safety Controller.

Cables

Appearance	Name	Length	Remarks	Model
	Single Connector Cable	2 m	Single connector cable to connect a 2-cable Mat (UM□□A-□-□-2) to a Controller. M8,3-socket	UMA-CBL-3PCF-M8-02M
		5 m		UMA-CBL-3PCF-M8-05M
		10 m		UMA-CBL-3PCF-M8-10M
	Male-Female Extension Cable	2 m	Extension cable to connect a 2-cable Mat (UM□□A-□-□-2) to a Controller. M8,3-pin	UMA-CBL-3PMF-M8-02M
		5 m		UMA-CBL-3PMF-M8-05M
		10 m		UMA-CBL-3PMF-M8-10M

Male-Male Extension Cable and Female-Female Extension Cable

Refer to *Connection Examples of Safety Mat and Controller* on page 8 for details on how to connect.

Appearance	Name	Length	Remarks	Model
	M8, 3-pin Male to Male Extension Cable	0.15 m	To be used to connect the connector sockets of 2-cable UMA Safety Mat together.	UMA-CBL-3PMM-M8-0.15M
	M8, 3-pin Female to Female Extension Cable	0.15 m	To be used to connect the connector plugs of 2-cable UMA Safety Mat together.	UMA-CBL-3PFF-M8-0.15M

Terminating Resistor

Appearance	Remarks	Model
 NEW	Terminating resistor, 8.2 kΩ To be used to connect a 2-cable Mat (UM□□A-□-□-2) to an SCC-1224A Safety Mat/Edge Controller.	UMA-TRES

UMA Series

Specifications

Safety Mat

Detection Method	Pressure sensitive
Mat Type	Normally open SPST
Mat Electrical Rating	20.4 V to 28.8 V
Activation Force	300 N min. to 80 mm dia. test piece
Maximum Load	2,000 N to 80 mm dia. test piece 1,862 kPa (270 lbs/in. ²) (rolling load (stationary))
Response Time	50 ms max.
Mechanical Durability	1 x 10 ⁶ operations min.
Mat Exit Cable	Model No. ending '-1': 1 exit cable, M8 4-pin cable, 4 conductors, 22 AWG, male Model No. ending '-2': 2 exit cables, M8 3-pin cable, 2 conductors, 22 AWG, 1 male and 1 female
Ambient operating temperature	-10 to 55°C (14 to 131°F) (with no icing or condensation)
Ambient storage temperature	-10 to 55°C (14 to 131°F) (with no icing or condensation)
Ambient operating humidity	0 to 95% RH
Degree of protection	IP65
Material (Mat cover)	Polyurethane
Weight	Approx. 25 kg/m ²

Safety Mat Controller

Ratings

Item	Model	MC3	SCC-1224A
Power voltage		24 VDC	120 VAC 50/60Hz (Terminals A1 and A2) 24 VAC 50/60Hz or 24 VDC (Terminals B1 and B2)
Operating voltage range		-15% to +15% of rated supply voltage	-10% to +10% of rated supply voltage
Power consumption *		3 W max.	120 VAC: 3.8 VA max. 50 Hz, 3.5 VA max. 60 Hz 24 VAC: 1.2 VA max., 24 VDC: 1.5 W max.
Rated load		6 A at 230 VAC/6 A at 24 VDC (resistive load) 5 A at 230 VAC (AC15)/2 A at 24 VDC (DC13) (inductive load)	3 A at 230 VAC/3 A at 24 VDC (resistive load) 1 A at 230 VAC (AC15)/2 A at 24 VDC (DC13) (inductive load)

* Power consumption of loads is not included.

Characteristics

Item	Model	MC3	SCC-1224A
Response time		30 ms max.	13 ms max.
Safety input		Mat can be connected in series (Connectable number: 12 max.) The external impedance must be 8 Ω or less between M11 and M21 and between M12 and M22.	Mat can be connected in series (Connectable number: 10 max.)
Safety output		SPDT-NO	SPDT-NO
Auxiliary output		SPDT-NC	SPST-NO
Dielectric strength	Between different poles of outputs	1,800 VAC, 50/60 Hz for 1 sec.	1,500 VAC, 50/60 Hz for 1 sec.
	Between power supply and output		
Vibration resistance		Malfunction: 10 to 55 Hz, 0.15 mm single amplitude	Malfunction: 10 to 55 Hz, 0.15 mm single amplitude
Mechanical shock resistance		Malfunction: 98 m/s ²	Malfunction: 147 m/s ²
Durability	Mechanical	10,000,000 cycles min.	1,000,000 cycles min.
	Electrical	100,000 cycles min. (rated load, switching frequency: 360 cycles/hour)	AC-15: 800,000 cycles min. (1A at 230 VAC) DC-13: 250,000 cycles min. (2A at 24 VDC)
Ambient operating temperature		0 to 55°C (with no icing or condensation)	-20 to 55°C (with no icing or condensation)
Ambient operating humidity		0% to 90% RH	0% to 90% RH
Degree of protection		IP20	IP20
Terminal tightening torque		0.5 N·m	0.5 to 0.6 N·m
Weight		Approx. 360 g	Approx. 210 g

Approvals

Item	Model	MC3	SCC-1224A
Conforming to Standards		EN ISO13856-1:2013, EN ISO13849-1:2015, ANSI/UL 508, CSA C22.2 No. 14	EN ISO 13856-1:2013, EN ISO 13849-1:2015, ANSI/UL 508, CSA C22.2 No. 14
Performance level (PL)/safety category *		PL d/safety category 3 (EN ISO 13849-1:2015)	PL d/safety category 3 (EN ISO 13849-1:2015)
PFHd *		4.8×10 ⁻⁸	6.5×10 ⁻⁹

* Applicable to integrated systems of UMA Safety Mats and Safety Mat Controller.

Installation

Using Trim Pieces

Ramp Trim with Yellow PVC Cover: UMRT4/UMRT8

Secures the edges of the Safety Mats to the floor.
It is composed of two parts with an aluminum base and a PVC Cover.

Joining Trim: UMJS4/UMJS8

The Joining Trims join the Safety Mats when two or more Safety Mats are being combined.

In addition to joining the Safety Mats, the Joining Trims preserve the Safety Mat's sensitivity at the joints.

Aluminum Ramp Trim: UMAL

Secures the edges of the Safety Mat to the floor.
The Aluminum Ramp Trim is hollow, so cable can be routed through it.

Molded Outside Corner: UMOC

Used together with the Ramp Trim with Yellow PVC Cover (UMRT4/UMRT8) to secure the external corners of the Safety Mats to the floor.

Molded Inside Corner: UMIC

Used together with the Ramp Trim with Yellow PVC Cover (UMRT4/UMRT8) to secure the internal corners of the Safety Mats to the floor.

Note: 1. The Aluminum Ramp Trim or Ramp Trim with Yellow PVC Cover must be cut to fit the size of the Safety Mats being used.

Furthermore, when the Safety Mat's wiring is being routed through the Aluminum Ramp Trim or Ramp Trim with Yellow PVC Cover, it will be necessary to cut or notch the Aluminum Ramp Trim or Ramp Trim with Yellow PVC Cover for cable access.

Refer to *UMA Safety Mat User Manual* (Man. No. Z375-E1) for details on cutting or notching the Aluminum Ramp Trim or Ramp Trim with Yellow PVC Cover.

2. The Joining Trim must be cut to fit the size of the Safety Mats being used.
3. The Ramp Trim with Yellow PVC Cover and Molded Corner must be anchored to the floor to secure the Safety Mats. It is also necessary to drill holes in the Trim and Molded Corner and anchoring it to the floor.

Safety Mat Configuration

The Safety Mats are secured by anchoring the Ramp Trim with Yellow PVC Cover and Molded Corner to the floor.

Before ordering, confirm the number of Ramp Trim with Yellow PVC Cover and Molded Corner pieces that will be needed.

Example 1: Using a Single Safety Mat

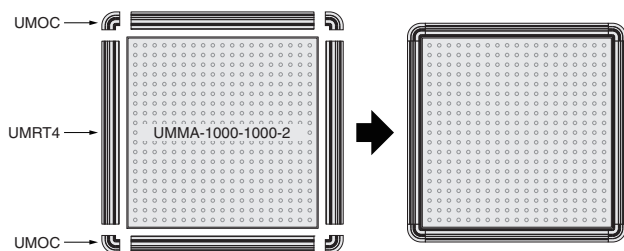

In this case, the perimeter of the Safety Mat is about 4 m and the following pieces are required:

The example above consists of the following components:

- UMMA-1000-1000 Safety Mat : 1 piece
- UMRT4 Ramp Trim with Yellow PVC Cover (1.22 m) : 4 pieces
- UMOC Molded Outside Corner : 4 pieces

Example 2: Using three Safety Mats

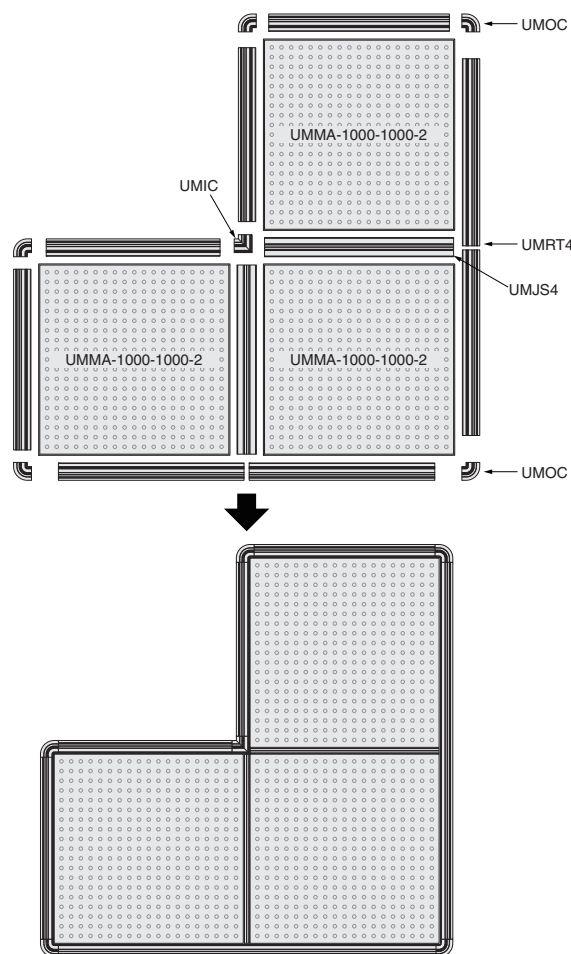

In this case, the perimeter of the Safety Mat is about 8 m, the joint between the Safety Mats is 2-m long, and the following pieces are required:

The example above consists of the following components:

- UMMA-1000-1000 Safety Mat : 3 pieces
- UMRT4 Ramp Trim with Yellow PVC Cover (1.22 m) : 8 pieces
- UMJS4 Joining Trim (1.22 m) : 2 pieces
- UMOC Molded Outside Corner : 5 pieces
- UMIC Molded Inside Corner : 1 piece

UMA Series

Connection Examples of Safety Mat and Controller

Using a Single Safety Mat

Connecting a 1-cable Mat (UM□□A-□-□-1) to a MC3 Safety Mat Controller or SCC-1224A Safety Mat/Edge Controller.

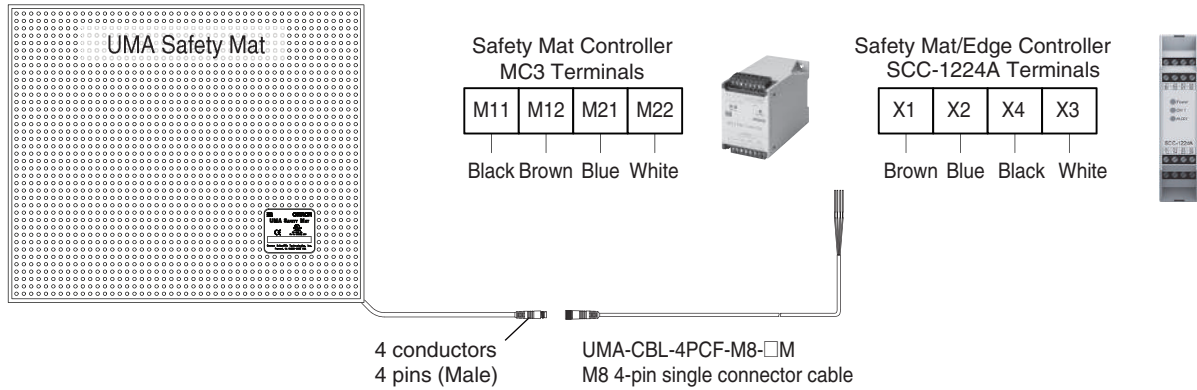

Using Multiple Safety Mats

- Connecting three 2-cable Mats (UM□□A-□-□-2) to a SCC-1224A Safety Mat/Edge Controller.

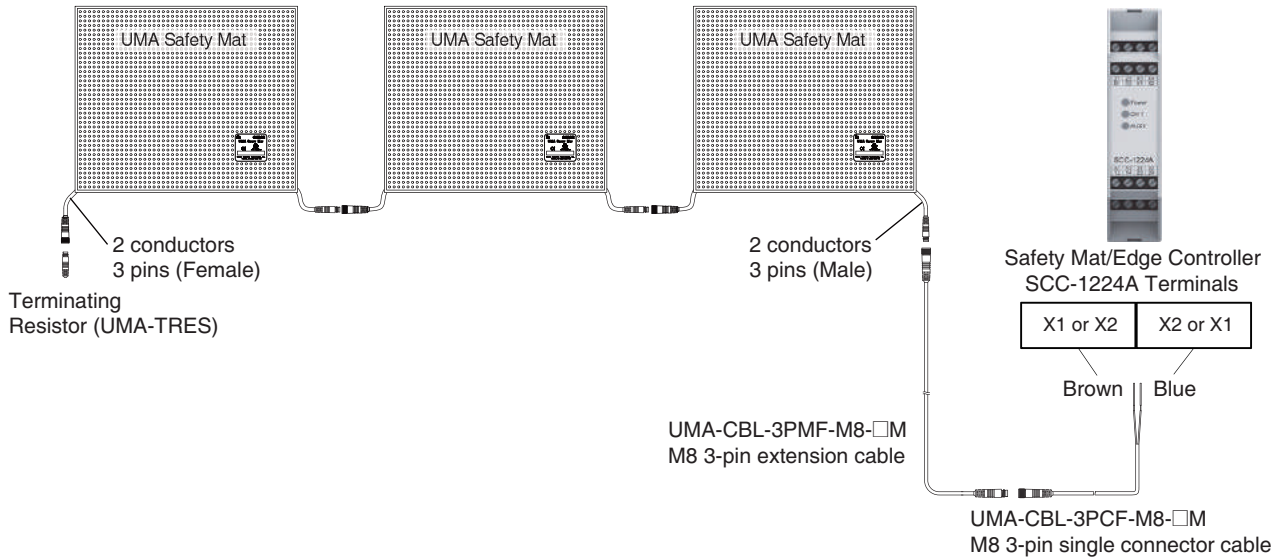

- Connecting three 2-cable Mats (UM□□A-□-□-2) to a MC3 Safety Mat Controller.

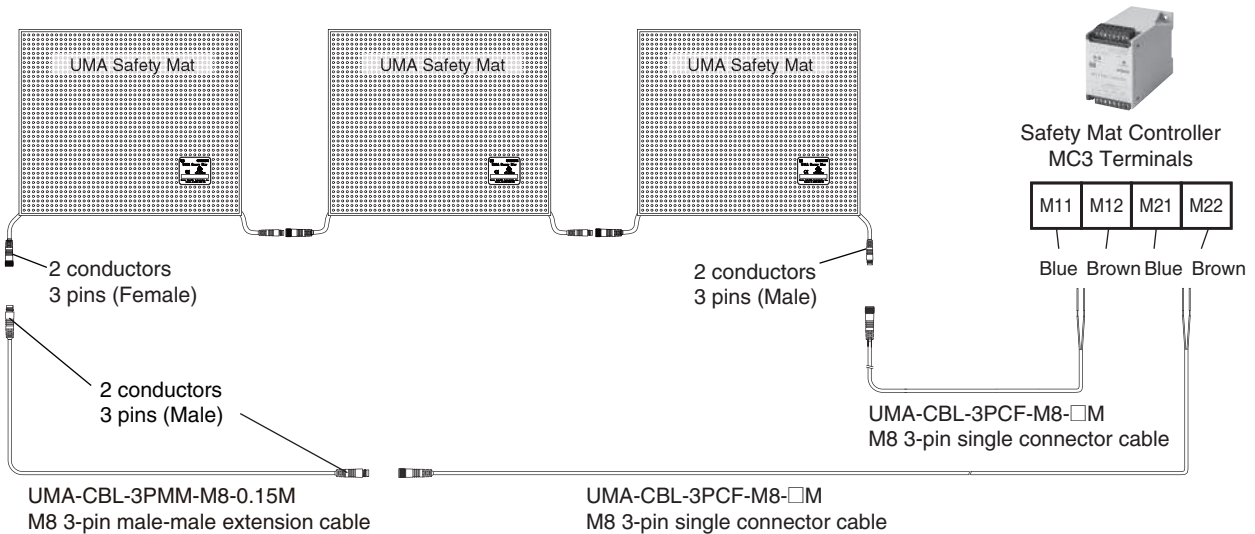

- Note:**
- When an MC3 is used, the total cable length is up to 100 m and up to 12 Safety Mats can be connected (up to 10 m² in total). When an SCC-1224A is used, the total cable length is up to 25 m and up to 10 Safety Mats can be connected (up to 10 m² in total). For the 1-cable type of UMA Safety Mat (UM□□A-□-□-1), the total lone length of cable must be calculated by multiplying the total length of the cables used by two.
 - The required accessories vary depending on the mat configuration and layout.

Connections

MC3

Internal Connection

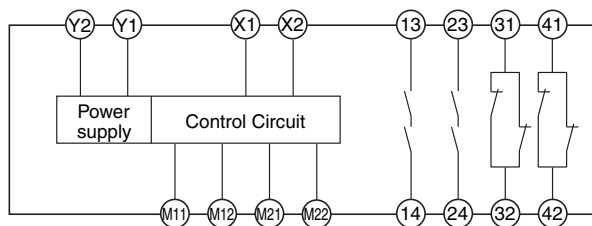

Wiring of Inputs and Outputs

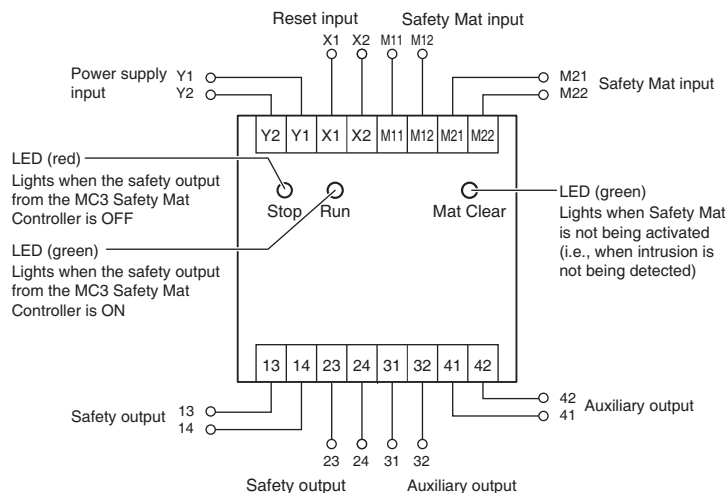

Signal name	Terminal name	Description of operation	Wiring
Power supply input	Y1, Y2	Power supply input terminals for MC3 Connect the power source to the Y1 and Y2 terminals.	Connect the power supply plus (24 VDC) to the Y1 terminal. Connect the power supply minus (GND) to the Y2 terminal.
Safety Mat input	M11, M12, M21, M22	To turn ON safety outputs, all the connected safety mats must have no load. Otherwise, the safety outputs will NOT turn ON.	
Reset input	X1, X2	The Safety Outputs can be turned ON only after the connection between X1 and X2 closes and then opens. If the connection between X1 and X2 does not close and open, the Safety Outputs will not turn ON.	Manual Reset Mode
		The normal operation can be made if the connection between X1 and X2 is open.	Auto Reset Mode
Safety output	13-14, 23-24	The Safety Outputs are turned ON and OFF according to the status of the Safety Mat inputs and the reset input.	Keep these outputs Open when NOT used.
Auxiliary output	31-32, 41-42	Turns ON/OFF according to the state of the opposite logic to the safety outputs.	Keep these outputs Open when NOT used.

Changing the Reset Mode

You can select either the Auto Reset Mode or the Manual Reset Mode with the MC3 Controller.

Remove the terminal block from the top of the MC3 Controller to expose three yellow jumpers. Set the jumps as required by system specifications.

Auto Reset Mode (Factory Setting)

Leave all three jumpers connected.

Terminal block removed
from top of Controller

Three yellow jumpers

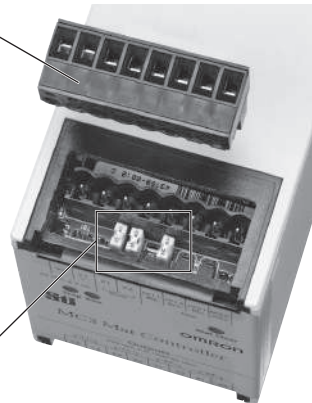

Manual Reset Mode

Remove all three jumpers.

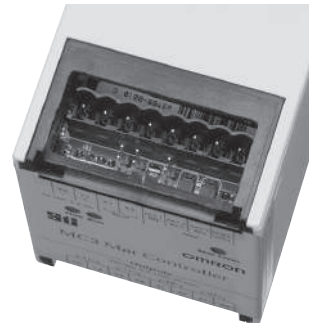

SCC-1224A Internal Connection

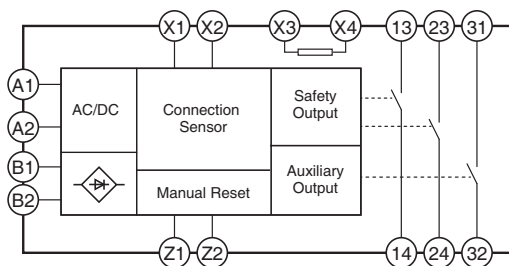

Wiring of Inputs and Outputs

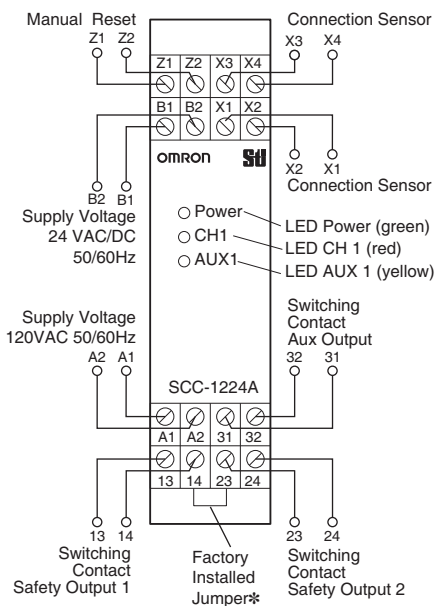

* Remove the factory-installed jumper between terminals 14 and 23 if safety outputs 1 and 2 are not connected in series.

Connection Terminals

Signal	Terminal	Overview	Wiring
Supply Voltage 120 VAC	A1, A2	Input terminals of 120 VAC supply voltage.	Do not connect a supply voltage of 24 VAC or 24 VDC.
Supply Voltage 24 VAC/DC	B1, B2	Input terminals of 24 VAC or 24 VDC supply voltage.	Do not connect a supply voltage of 120 VAC. When using 24 VDC, connect 24 VDC line to B1 and 0 VDC line to B2.
Connection Sensor	X1, X2	Input terminals of sensor signal.	Connect signal lines of UMA Safety Mat. For 1-cable type of UMA Safety Mat (UM□□A-□-□-1), connect brown line to X1 and blue line to X2.
	X3, X4		Connect signal lines of 1-cable type of UMA Safety Mat (UM□□A-□-□-1), white line to X3 and black line to X4.
Manual Reset	Z1, Z2	Input terminals of a reset switch (NO contact). Also used as external device monitoring (EDM) terminals of contactors.	Do not connect any lines when in the automatic reset mode. Connect NC contacts of contactors when using the external device monitoring (EDM) function.
Safety Output 1	13-14	Closed or open according to sensor and manual reset inputs.	Do not connect any lines when not used. Remove the factory-installed jumper between terminals 14 and 23 if safety outputs 1 and 2 are not connected in series.
Safety Output 2	23-24		
Auxiliary Output	31-32	In the auxiliary output without delay mode, the auxiliary output is closed without delay when the safety outputs are open. In the auxiliary output delayed mode, the auxiliary output is closed with a delay of 0.5 s after the safety outputs are open, and remains closed for 3 s.	Do not connect any lines when not used. Do not use this as safety output.

Signal Indicators

Label	Color	Name	Status	Description
Power	Green	Power LED	ON	Operating state
			Flashing	Fault alarm
CH1	Red	Sensor Input LED	ON	Sensor activated (Safety output OFF)
			Fast flashing (approx. 4 Hz)	Sensor faulty
			Slow flashing (approx. 1 Hz)	Waiting for reset switch input (Safety output OFF)
AUX1	Yellow	Auxiliary output LED	OFF	Released from interlocked state (Safety output ON)
			ON	Auxiliary output contact closed
			OFF	Auxiliary output contact open

UMA Series

Dimensions

(Unit: mm)

Safety Mat

1-cable mat

UM□□A-□-□-1

The UM□□A-□-□-1 mat comes with a short 4-conductor quick disconnect cables with M8 4-pin connector at a corner of the safety mat.

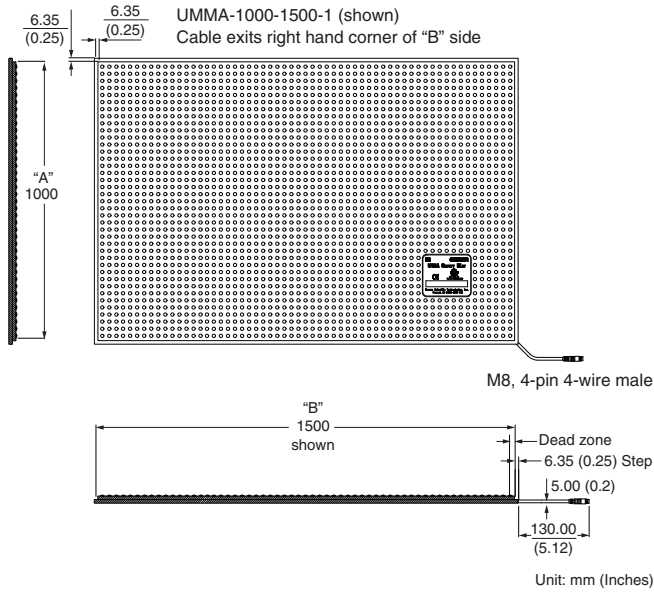

2-cable mat

UM□□A-□-□-2

The UM□□A-□-□-2 mat comes with two short 2-conductor quick disconnect cables with M8 3-pin connector at two corners of the safety mat.

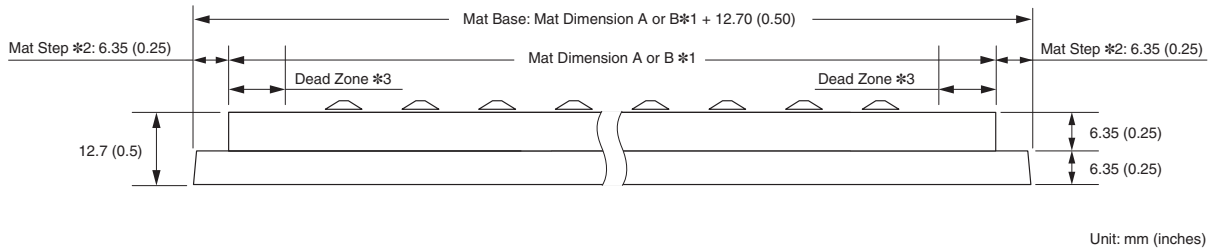
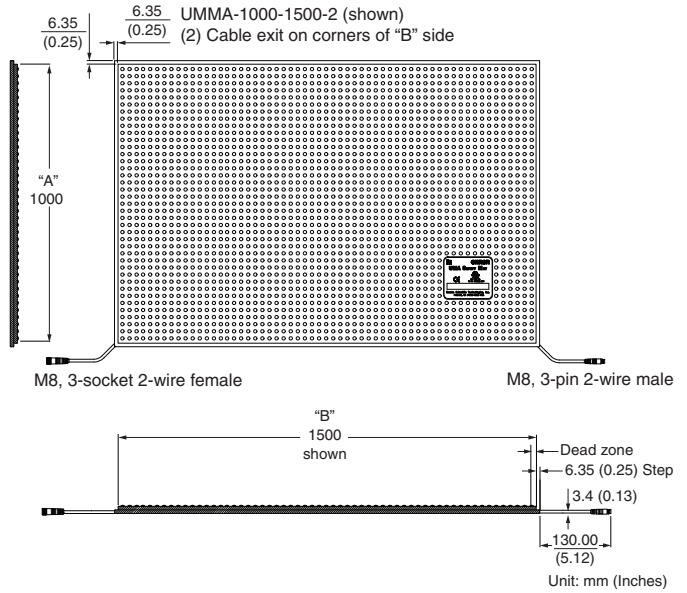

*1. Refer to Model Number Structure on page 1 for more information.

*2. "Step" portion of mat (inactive) is used to "seat/place/hold" trim.

*3. The mat has the following inactive (non-sensing) area:

- 10 mm (20 mm at corners) with a test piece of 80 mm diameter
- 15 mm (30 mm at corners) with a test piece of 11 mm diameter

Example dimensions: UMMA-0500-0500-□

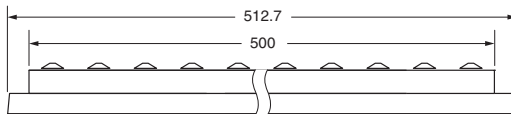

(Unit: mm)

Mat Controller MC3

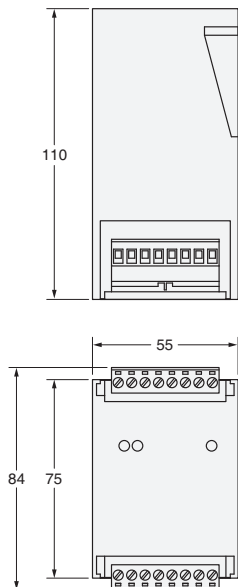

Terminal/LED arrangements

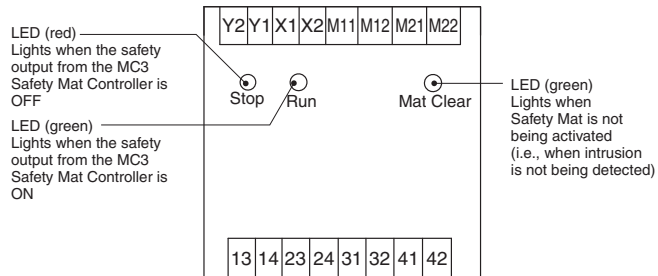

Safety Mat/Edge Controller SCC-1224A

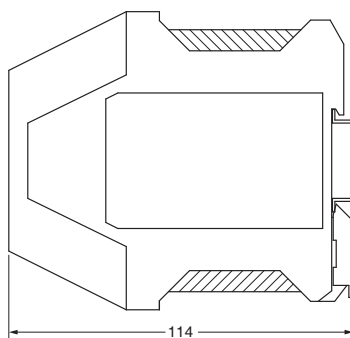
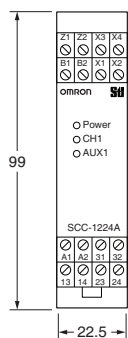

Terminal arrangements

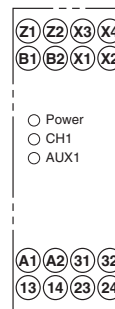

Accessories

Cables

Using with 1-Cable Mats

Single Connector Cable (M8, 4-socket)

Single connector cable to connect a 1-cable UMA Safety Mat to a MC3 Safety Mat Controller, SCC-1224A Safety Mat/Edge Controller or NX-series Safety Controller.

UMA-CBL-4PCF-M8-□M

Model	L (m)
UMA-CBL-4PCF-M8-02M	2
UMA-CBL-4PCF-M8-05M	5
UMA-CBL-4PCF-M8-10M	10

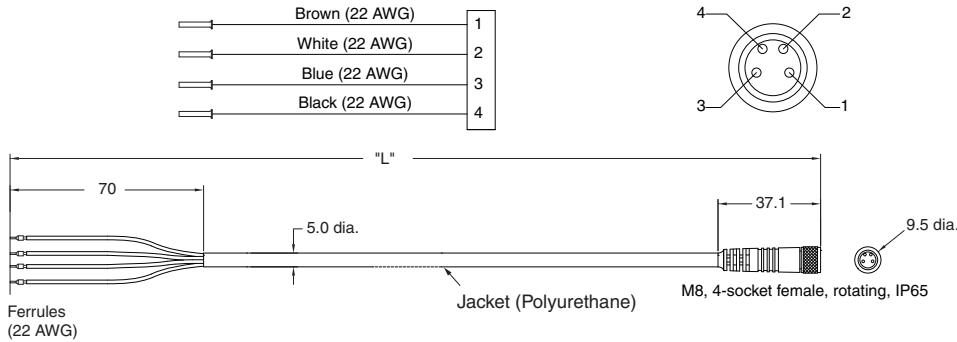

Male-Female Extension Cable (M8, 4-pin)

Extension cable to connect a 1-cable UMA Safety Mat to a UMA-CBL-4PCF-M8-□M Single Connector Cable.

UMA-CBL-4PMF-M8-□M

Model	L (m)
UMA-CBL-4PMF-M8-02M	2
UMA-CBL-4PMF-M8-05M	5
UMA-CBL-4PMF-M8-10M	10

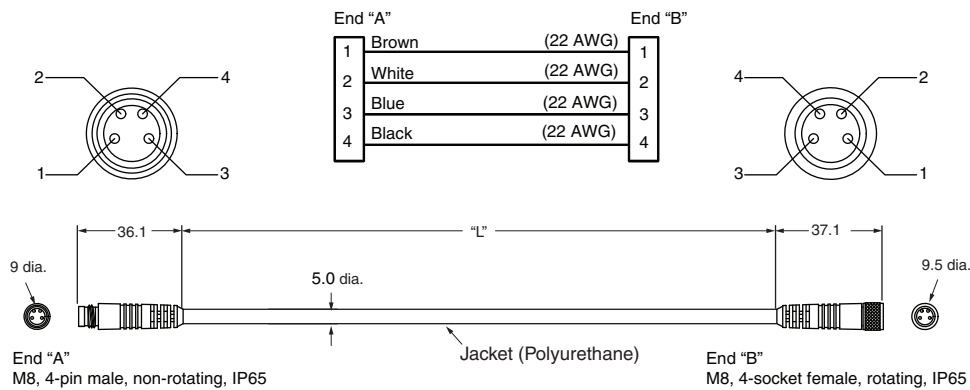

Using with 2-Cable Mats

Single Connector Cable (M8, 3-socket)

Single connector cable to connect a 2-cable UMA Safety Mat to a MC3 Safety Mat Controller, SCC-1224A Safety Mat/Edge Controller or NX-series Safety Controller.

UMA-CBL-3PCF-M8-□M

Model	L (m)
UMA-CBL-3PCF-M8-02M	2
UMA-CBL-3PCF-M8-05M	5
UMA-CBL-3PCF-M8-10M	10

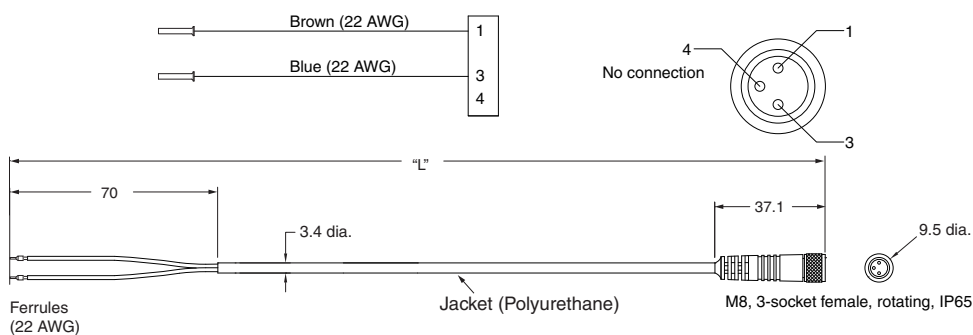

Male-Female Extension Cable (M8, 3-pin)

Extension cable to connect a 2-cable UMA Safety Mat to a UMA-CBL-3PCF-M8-□M Single Connector Cable or connect multiple 2-cable UMA Safety Mats in series.

UMA-CBL-3PMF-M8-□M

Model	L (m)
UMA-CBL-3PMF-M8-02M	2
UMA-CBL-3PMF-M8-05M	5
UMA-CBL-3PMF-M8-10M	10

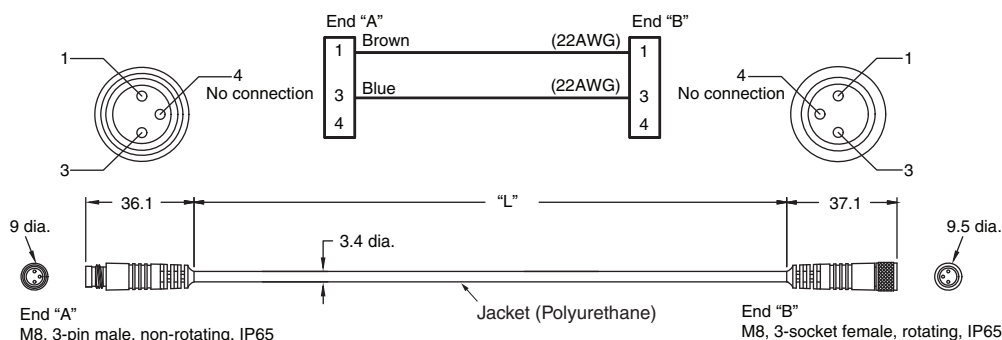

Male-Male Extension Cable (M8, 3-pin)

Used to connect the connector sockets of 2-cable UMA Safety Mats together.

UMA-CBL-3PMM-M8-0.15M

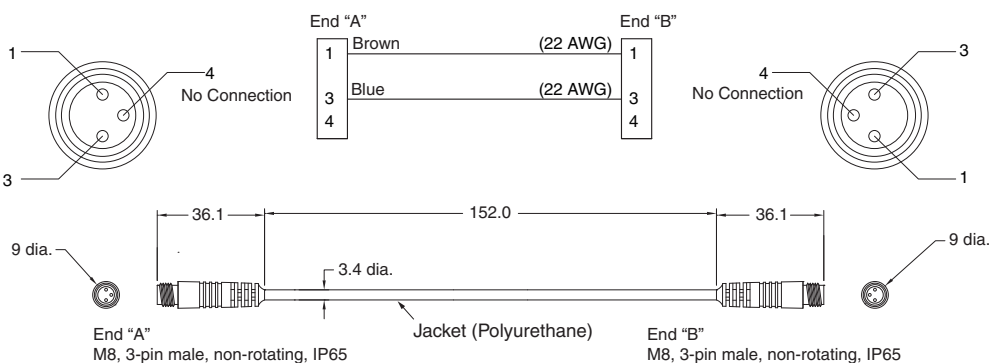

Female-Female Extension Cable (M8, 3-pin)

Used to connect the connector plugs of 2-cable UMA Safety Mats together.

UMA-CBL-3PFF-M8-0.15M

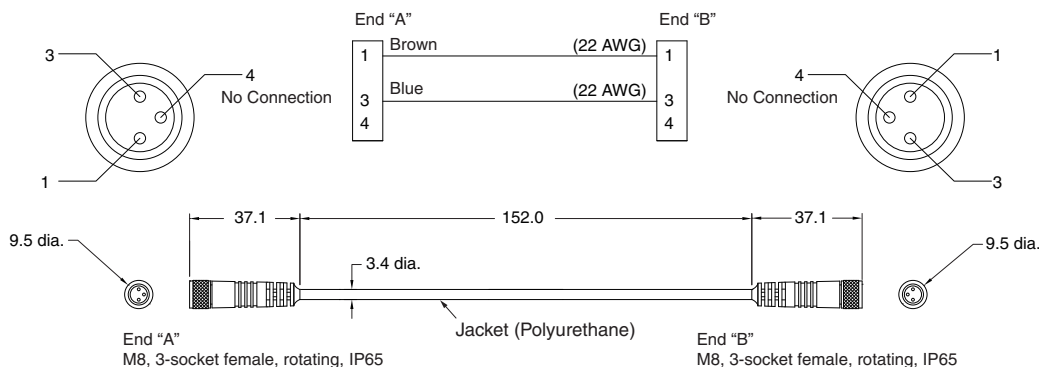

Terminating Resistor

Used to connect a 2-cable Mat (UM□□A-□□-2) to an SCC-1224A Safety Mat/Edge Controller.

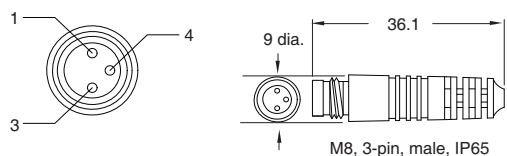

Trims

Ramp Trim with Yellow PVC Cover UMRT□

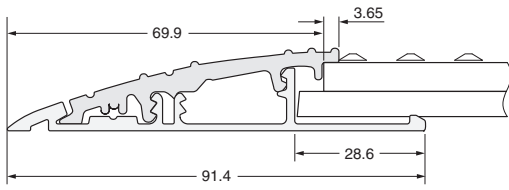

Joining Trim UMJS□

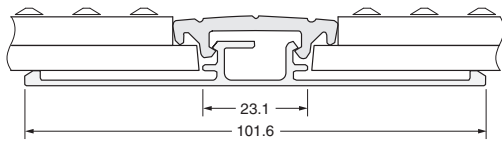

Aluminum Ramp Trim UMAL

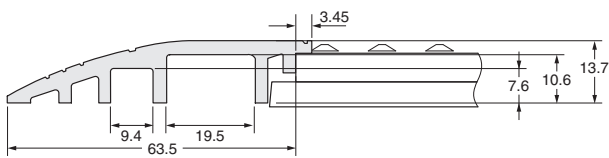

Molded Outside Corner UMOC

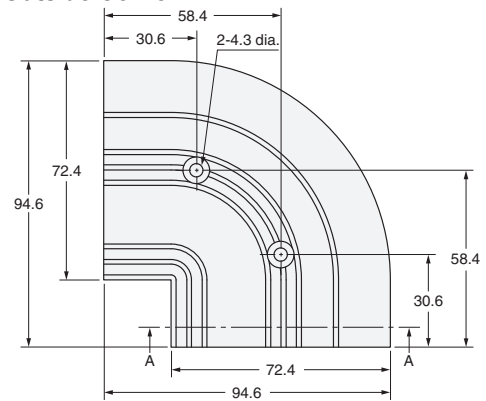

Molded Inside Corner UMIC

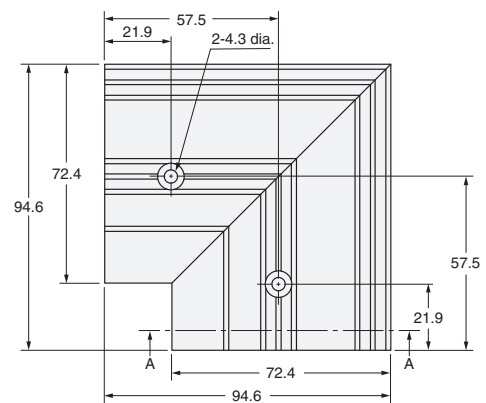

Application Examples

Highest achievable PL/ safety category	Model	Stop category	Reset
PLd/3 equivalent	Safety Mat UMA series Mat Controller MC3	0	Manual

Note: The above PL is only the evaluation result of the example. The PL must be evaluated in an actual application by the customer after confirming the usage conditions.

Application Overview

- The power supply to the motor M is turned OFF when a person steps on the mat.
- The power supply to the motor M is kept OFF until the reset switch S1 is pressed after the person steps out of the mat.

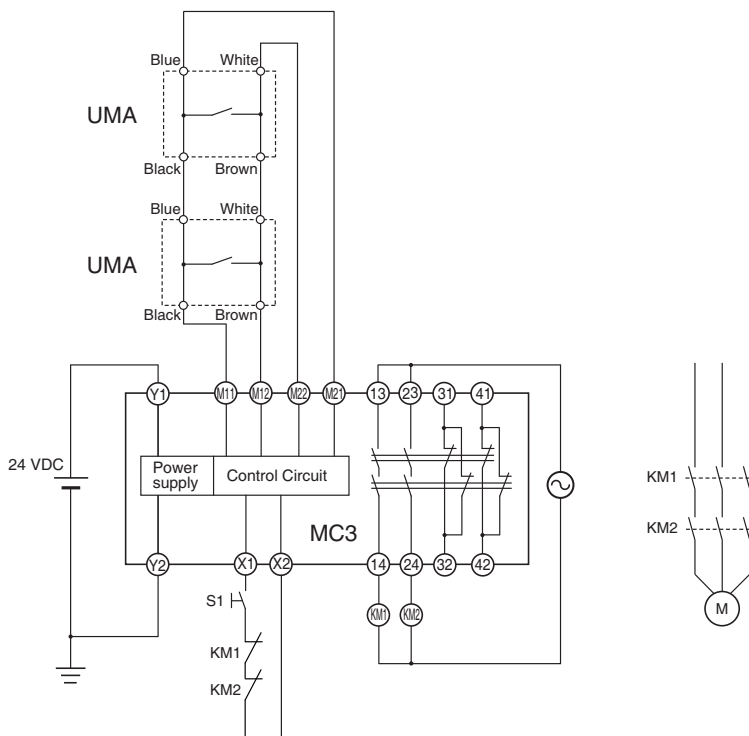

S1: Reset switch
 KM1, KM2: Magnetic contactor
 M: Motor

Timing Chart

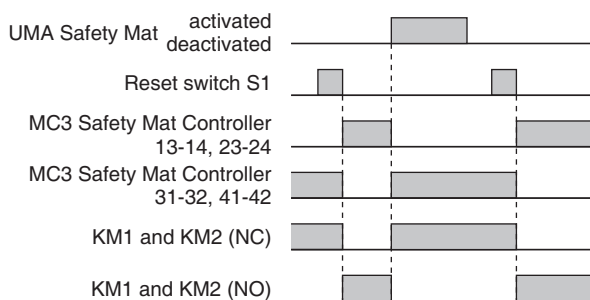

Note: Remove the three yellow jumpers from the MC3 to use Manual Reset Mode. Refer to *Changing the Reset Mode* on page 10 for the location of the jumpers.

UMA Series

Highest achievable PL/ safety category	Model	Stop category	Reset
PLd/3 equivalent	Safety Mat UMA series Mat Controller MC3 Safety Relay Unit G9SA-301	0	Auto

Note: The above PL is only the evaluation result of the example. The PL must be evaluated in an actual application by the customer after confirming the usage conditions.

Application Overview

- The power supply to the motor M is turned OFF when a person steps on the mat.
- The power supply to the motor M is kept OFF until the person steps out of the mat.

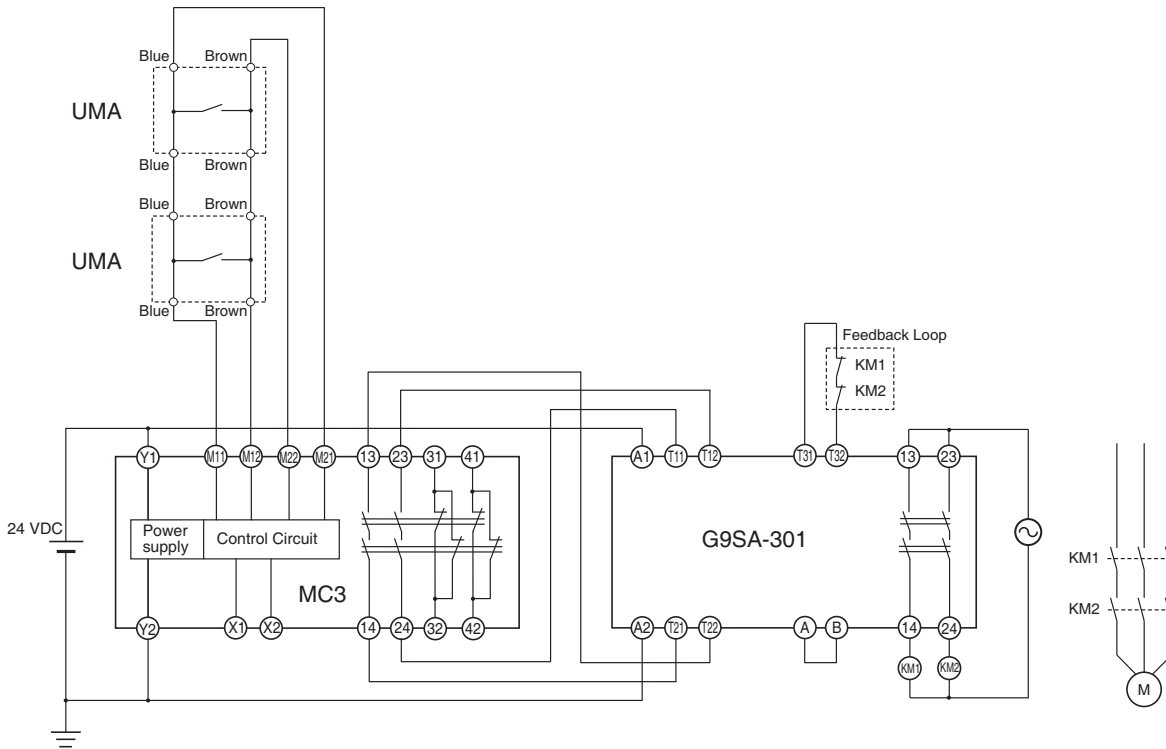

KM1, KM2: Magnetic contactor
M: Motor

Timing Chart

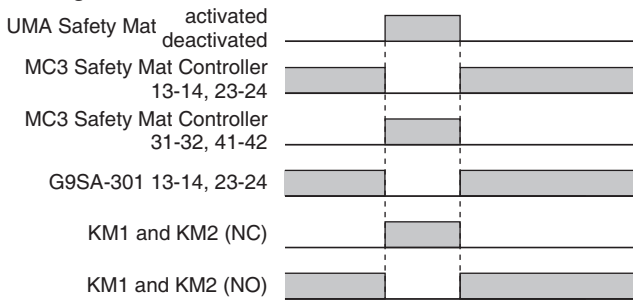

Note: Attach the three yellow jumpers to the MC3 to use Automatic Reset Mode. Refer to *Changing the Reset Mode* on page 10 for the location of the jumpers.

Highest achievable PL/ safety category	Model	Stop category	Reset
PLd/3 equivalent	Safety Mat UMA series Safety Mat/Edge Controller SCC-1224A	0	Manual

Note: The above PL is only the evaluation result of the example. The PL must be evaluated in an actual application by the customer after confirming the usage conditions.

Application Overview

- The power supply to the motor M is turned OFF when a person steps on the mat.
- The power supply to the motor M is kept OFF until the reset switch S1 is pressed after the person steps out of the mat.

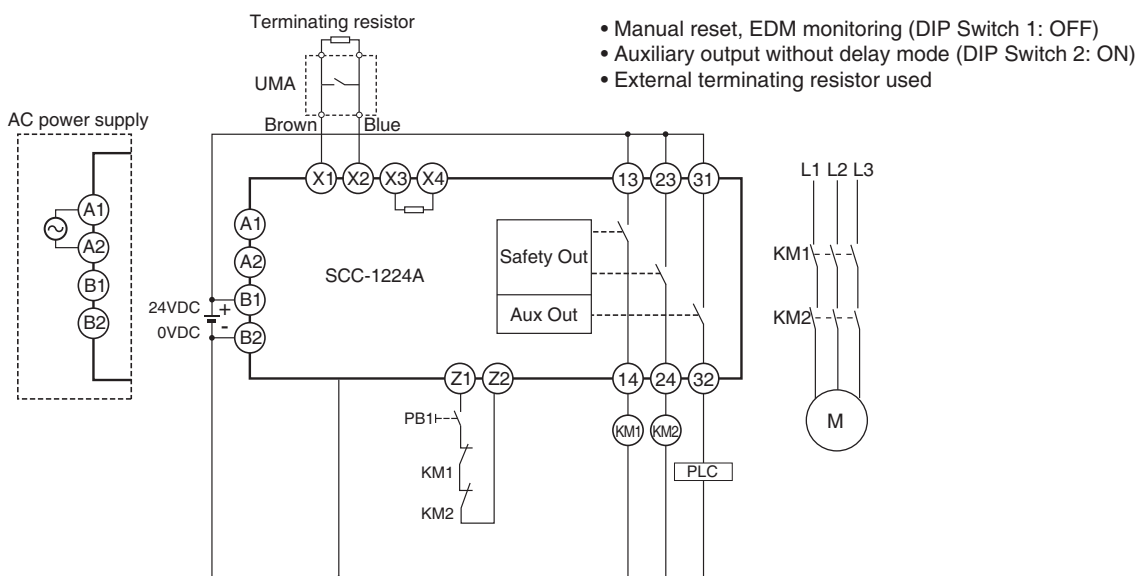

S1: Reset switch
KM1, KM2: Magnetic contactor
M: Motor

Timing Chart

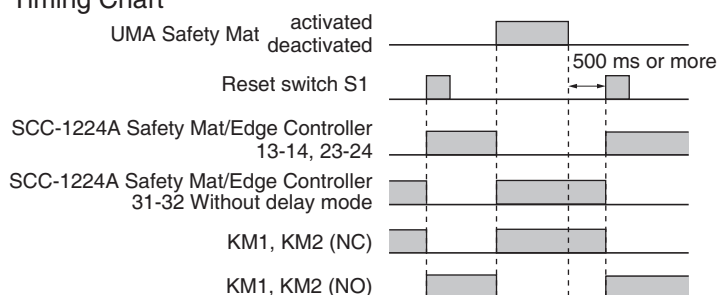

UMA Series

Highest achievable PL/ safety category	Model	Stop category	Reset
PLd/3 equivalent	Safety Mat UMA series Safety Mat/Edge Controller SCC-1224A Safety Relay Unit G9SA-301	0	Auto

Note: The above PL is only the evaluation result of the example. The PL must be evaluated in an actual application by the customer after confirming the usage conditions.

Application Overview

- The power supply to the motor M is turned OFF when a person steps on the mat.
- The power supply to the motor M is kept OFF until the person steps out of the mat.

- Automatic reset (DIP Switch1: ON)
- Auxiliary output without delay mode (DIP Switch 2: ON)
- Internal terminating resistor used

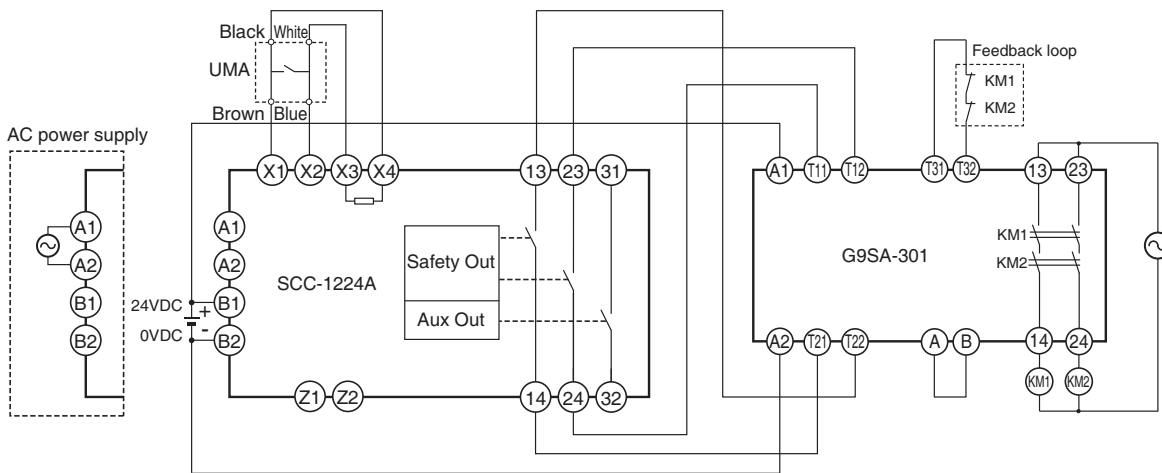

KM1, KM2: Magnetic contactor
M: Motor

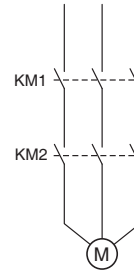

Timing Chart

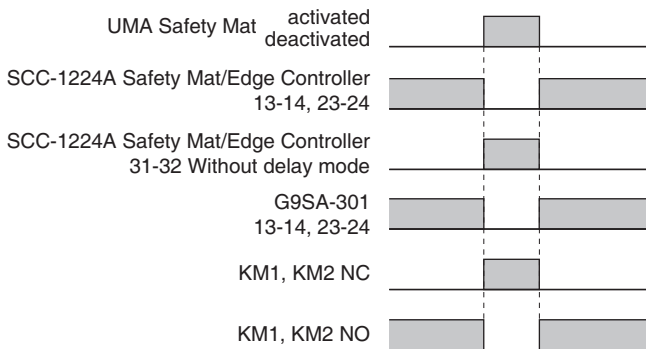

Related Manuals

Man. No.	Model	Manual name
Z375	UMA	UMA Safety Mat User Manual
Z394	SCC-1224A	SCC-1224A Safety Mat/Edge Controller User Manual

Terms and Conditions Agreement

Read and understand this catalog.

Please read and understand this catalog before purchasing the products. Please consult your OMRON representative if you have any questions or comments.

Warranties.

- (a) Exclusive Warranty. Omron's exclusive warranty is that the Products will be free from defects in materials and workmanship for a period of twelve months from the date of sale by Omron (or such other period expressed in writing by Omron). Omron disclaims all other warranties, express or implied.
- (b) Limitations. OMRON MAKES NO WARRANTY OR REPRESENTATION, EXPRESS OR IMPLIED, ABOUT NON-INFRINGEMENT, MERCHANTABILITY OR FITNESS FOR A PARTICULAR PURPOSE OF THE PRODUCTS. BUYER ACKNOWLEDGES THAT IT ALONE HAS DETERMINED THAT THE PRODUCTS WILL SUITABLY MEET THE REQUIREMENTS OF THEIR INTENDED USE.

Omron further disclaims all warranties and responsibility of any type for claims or expenses based on infringement by the Products or otherwise of any intellectual property right. (c) Buyer Remedy. Omron's sole obligation hereunder shall be, at Omron's election, to (i) replace (in the form originally shipped with Buyer responsible for labor charges for removal or replacement thereof) the non-complying Product, (ii) repair the non-complying Product, or (iii) repay or credit Buyer an amount equal to the purchase price of the non-complying Product; provided that in no event shall Omron be responsible for warranty, repair, indemnity or any other claims or expenses regarding the Products unless Omron's analysis confirms that the Products were properly handled, stored, installed and maintained and not subject to contamination, abuse, misuse or inappropriate modification. Return of any Products by Buyer must be approved in writing by Omron before shipment. Omron Companies shall not be liable for the suitability or unsuitability or the results from the use of Products in combination with any electrical or electronic components, circuits, system assemblies or any other materials or substances or environments. Any advice, recommendations or information given orally or in writing, are not to be construed as an amendment or addition to the above warranty.

See <http://www.omron.com/global/> or contact your Omron representative for published information.

Limitation on Liability; Etc.

OMRON COMPANIES SHALL NOT BE LIABLE FOR SPECIAL, INDIRECT, INCIDENTAL, OR CONSEQUENTIAL DAMAGES, LOSS OF PROFITS OR PRODUCTION OR COMMERCIAL LOSS IN ANY WAY CONNECTED WITH THE PRODUCTS, WHETHER SUCH CLAIM IS BASED IN CONTRACT, WARRANTY, NEGLIGENCE OR STRICT LIABILITY.

Further, in no event shall liability of Omron Companies exceed the individual price of the Product on which liability is asserted.

Suitability of Use.

Omron Companies shall not be responsible for conformity with any standards, codes or regulations which apply to the combination of the Product in the Buyer's application or use of the Product. At Buyer's request, Omron will provide applicable third party certification documents identifying ratings and limitations of use which apply to the Product. This information by itself is not sufficient for a complete determination of the suitability of the Product in combination with the end product, machine, system, or other application or use. Buyer shall be solely responsible for determining appropriateness of the particular Product with respect to Buyer's application, product or system. Buyer shall take application responsibility in all cases.

NEVER USE THE PRODUCT FOR AN APPLICATION INVOLVING SERIOUS RISK TO LIFE OR PROPERTY OR IN LARGE QUANTITIES WITHOUT ENSURING THAT THE SYSTEM AS A WHOLE HAS BEEN DESIGNED TO ADDRESS THE RISKS, AND THAT THE OMRON PRODUCT(S) IS PROPERLY RATED AND INSTALLED FOR THE INTENDED USE WITHIN THE OVERALL EQUIPMENT OR SYSTEM.

Programmable Products.

Omron Companies shall not be responsible for the user's programming of a programmable Product, or any consequence thereof.

Performance Data.

Data presented in Omron Company websites, catalogs and other materials is provided as a guide for the user in determining suitability and does not constitute a warranty. It may represent the result of Omron's test conditions, and the user must correlate it to actual application requirements. Actual performance is subject to the Omron's Warranty and Limitations of Liability.

Change in Specifications.

Product specifications and accessories may be changed at any time based on improvements and other reasons. It is our practice to change part numbers when published ratings or features are changed, or when significant construction changes are made. However, some specifications of the Product may be changed without any notice. When in doubt, special part numbers may be assigned to fix or establish key specifications for your application. Please consult with your Omron's representative at any time to confirm actual specifications of purchased Product.

Errors and Omissions.

Information presented by Omron Companies has been checked and is believed to be accurate; however, no responsibility is assumed for clerical, typographical or proofreading errors or omissions.

Note: Do not use this document to operate the Unit.

OMRON Corporation Industrial Automation Company

Kyoto, JAPAN

Contact : www.ia.omron.com

Regional Headquarters

OMRON EUROPE B.V.

Wegalaan 67-69, 2132 JD Hoofddorp
The Netherlands
Tel: (31) 2356-81-300 Fax: (31) 2356-81-388

OMRON ELECTRONICS LLC

2895 Greenspoint Parkway, Suite 200
Hoffman Estates, IL 60169 U.S.A.
Tel: (1) 847-843-7900 Fax: (1) 847-843-7787

OMRON ASIA PACIFIC PTE. LTD.

438B Alexandra Road, #08-01/02 Alexandra
Technopark, Singapore 119968
Tel: (65) 6835-3011 Fax: (65) 6835-2711

OMRON (CHINA) CO., LTD.

Room 2211, Bank of China Tower,
200 Yin Cheng Zhong Road,
PuDong New Area, Shanghai, 200120, China
Tel: (86) 21-5037-2222 Fax: (86) 21-5037-2200

Authorized Distributor:

©OMRON Corporation 2017-2022 All Rights Reserved.
In the interest of product improvement,
specifications are subject to change without notice.

CSM_2_2

Cat. No. A250-E1-03 1122 (0317)